

ASSEMBLY INSTRUCTION

HAROLD

SOFA TABLE

ITEM CODE 716590001

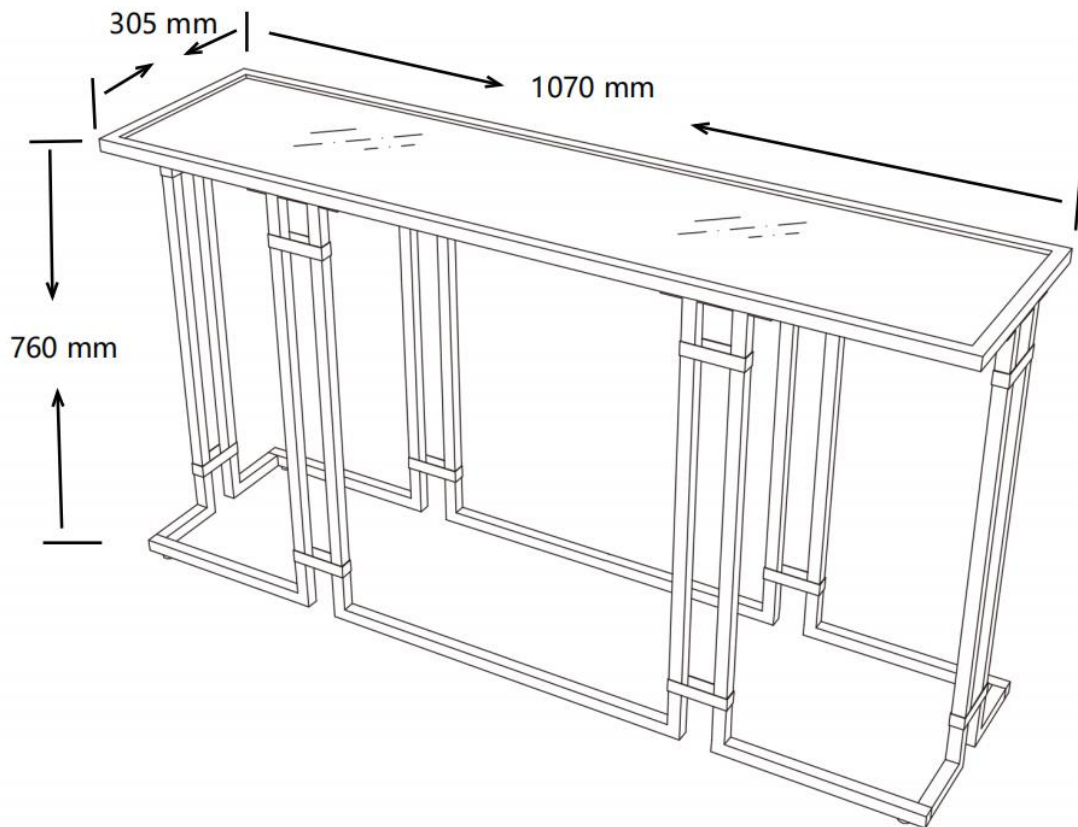



Imported by JWA Furniture Pty Ltd, Qld, Brisbane Australia.
For any assistance with assembly or for missing parts please refer to your receipt

PRE-ASSEMBLY PREPARATION

Before you start:

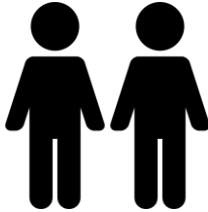
1. Choose a clean, level, spacious assembly area. Avoid hard surfaces that may damage the product
2. Take care when lifting. Product should be assembled as near as possible to the point of use
3. Ensure that you have all required contents for complete assembly
4. Always read the assembly instructions carefully before beginning assembly.
5. Keep all hardware parts and packaging out of reach of small children.
6. Do not over tighten the screws and bolts as this may damage the threads
7. Assembly is to be carried out by a competent adult(s) ONLY
8. During assembly, children should be kept away from the product due to possible risk to injury.
9. Do not use this item if any components are missing or damaged.
10. Please keep the instructions for future reference.

		
Allow 15 min	For 1 person	Additional tool required



TIPPING WARNING





Serious or fatal injuries may occur from furniture toppling over. To help avoid this please follow the below recommendations:

- Install the provided "Tipping Kit" as per the instructions
- Never allow children to climb on or hang off of any part of this product
- Unless specifically designed to accommodate, do not set TVs or other heavy objects on top of this product





If this product has drawers:

- Place the heaviest items in lowest drawers
- Do not open more than 1 drawer at a time as this may cause the product to become unbalanced
- Do not tamper with or remove any drawer interlocking/running system

Note: The use of the provided "Tipping Kit" may reduce but not necessarily eliminate the risk of furniture toppling over. Please use this product with caution.

This is a permanent label. Do not attempt to remove!

PARTS LIST

	A	M6X10MM	BOLT	16 PCS
	B		HEX KEY	1 PC
	C		POLISHING CLOTH	1 PC
	D		FOOT	4 PCS

1	Top Panel x1
2	Side Frame x2
3	Front Frame x2

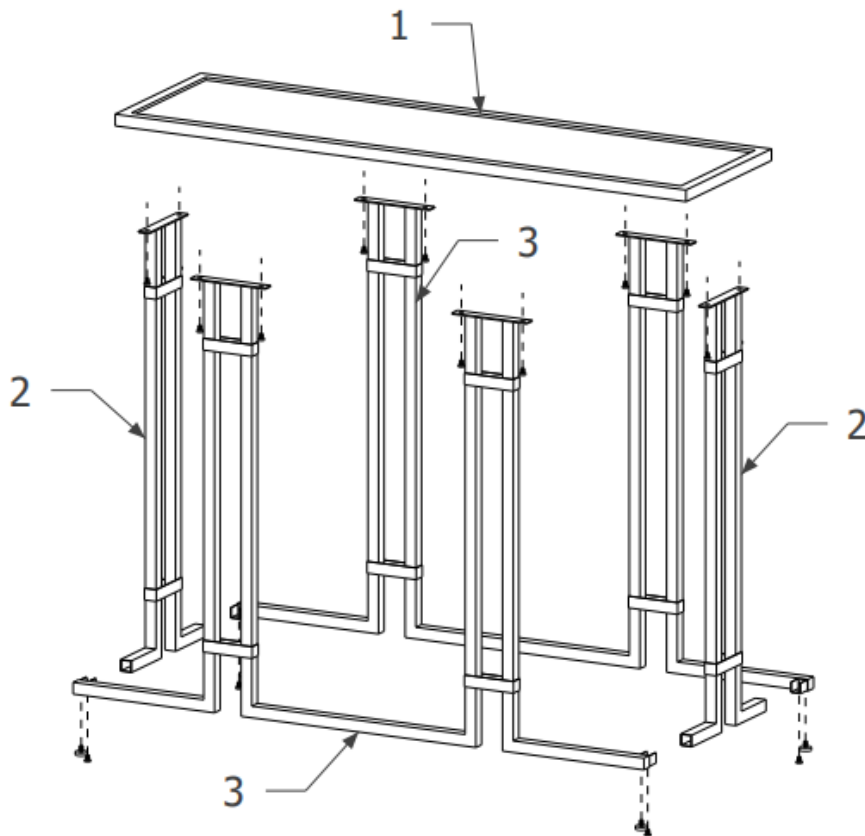

STEP 1:

- Prepare a surface with a protective blanket or cardboard.
- Connect side frame(2) to front frame(3) as shown
- Secure with bolt(A) per connection. Fasten with allen key(B).
- Fasten only until the bolt is tight in the thread, do not fully fasten for now.
- Screw foot(D) to unit as shown

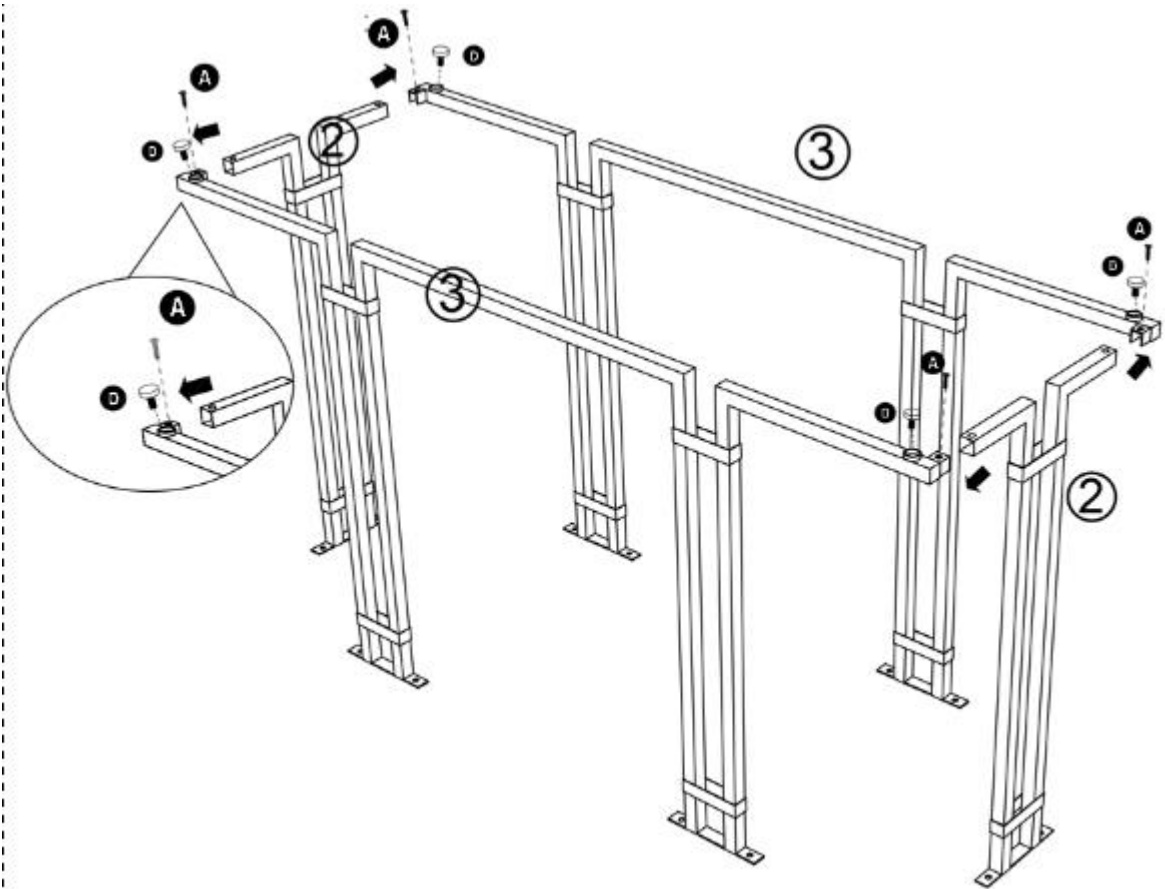

STEP 2:

- Connect top panel(1) to unit as shown.
- Secure with bolt(A) per connection. Fasten with allen key(B).
- Once levelled turn the table back on its side and fasten all the bolts.

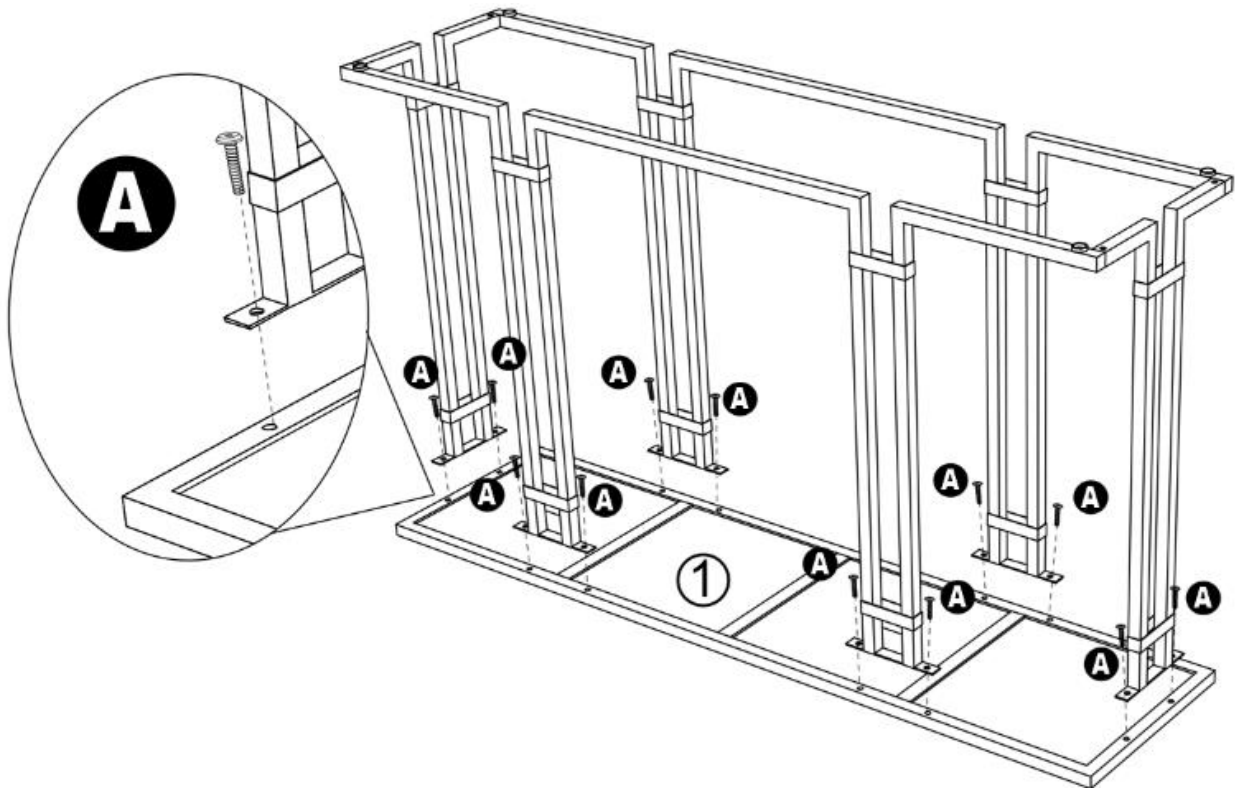

ASSEMBLY IS COMPLETE

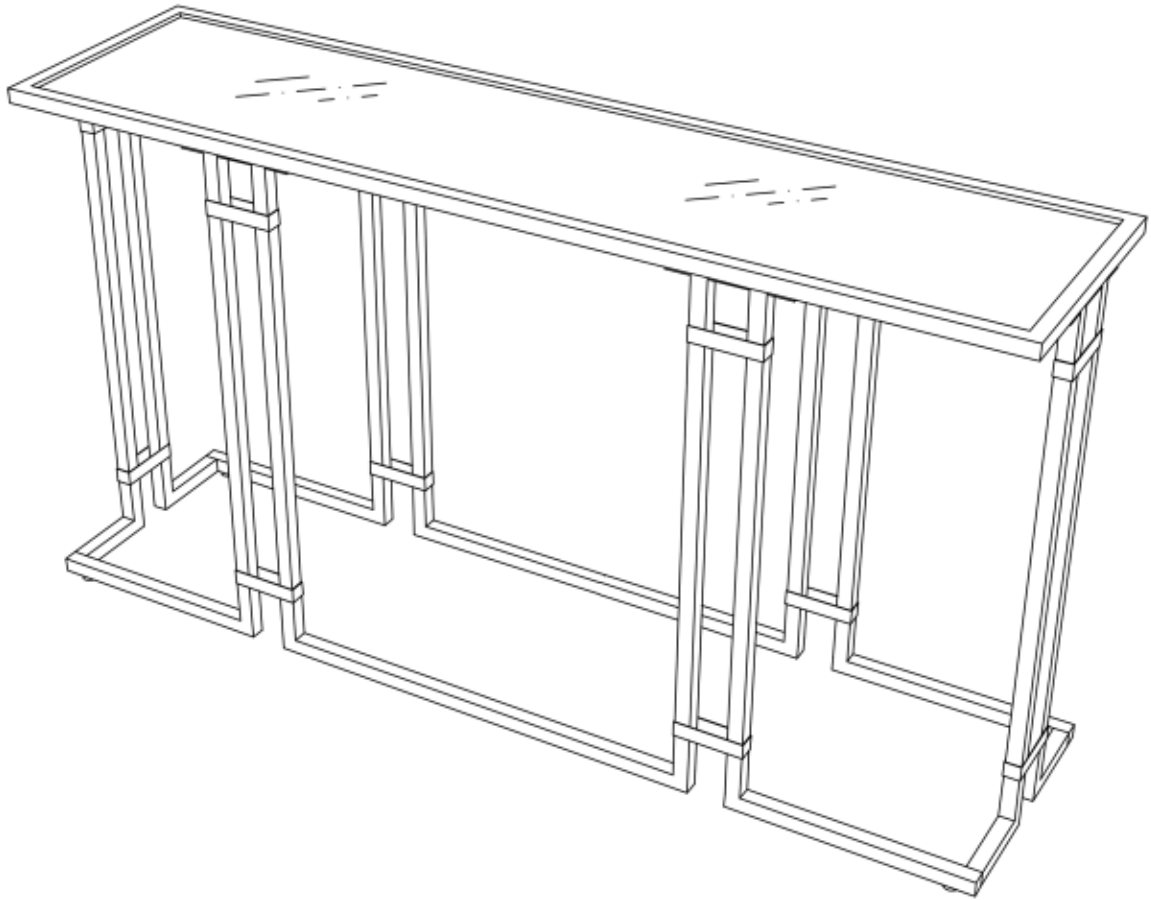

SAFETY BRACKETS INSTRUCTIONS

1. Attach one Mounting Plate to the wall with the Large Screws. Make sure to attach the Mounting Plate into a stud. If mounting into brick or masonry you will need to acquire wall anchors.
2. Attach the second Mounting Plate to the furniture frame with the Short Screws.
3. Move the furniture to its final position. Thread a Wall Strap through the both Mounting Plates and tighten until snug. Do not over tighten.
4. Make sure that the Mounting Plates are firmly attached to the wall and furniture and that the Wall Strap is snug.

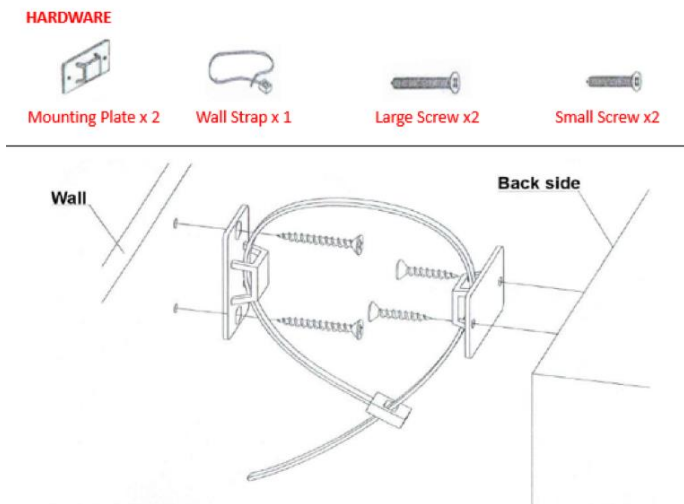

PRODUCT CARE:

If the glass is chipped or broken, stop using the product and consult place of purchase

WARNING:

- Do not place very hot or cold items directly onto the glass surface, unless a coaster or placemat are used to prevent the items from coming into direct contact with the glass
- Do not sit or stand upon the glass surface
- Do not use the glass as a chopping surface
- Do not strike the glass with hard or pointed items
- When cleaning glass panels use a damp cloth or lather with washing up liquid or soft soap if necessary. Do not use any cleaning substances that contain abrasive properties, as these could scratch or damage the glass.